



VT-012LC™ Autotracking Antenna

The VT-012LC is a dual axis 1.2m parabolic reflector autotracking antenna, it is self contained and is simple to setup and operate. The VT-012LC has a dual polarization head that can receive signals with gains of L band 22dBi, S band 26dBi, C band 32dBi and track using a digital rotary scan autotracking technique with continuous rotation in azimuth via slip ring assemblies with dual channel rotary joints.



VT-012LC Autotracking Antenna

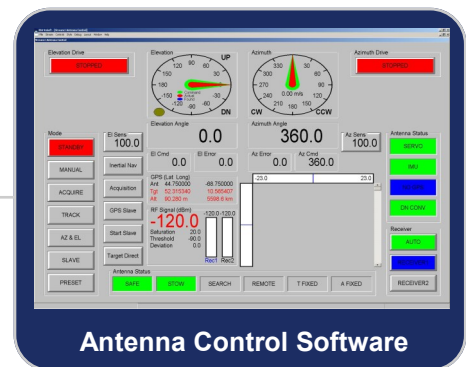

Antenna Control Software

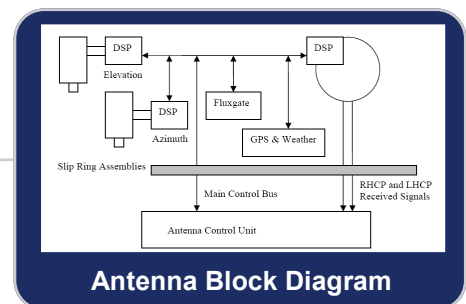

Antenna Block Diagram

Features

- Simultaneous RHCP/LHCP or Vertical/ Horizontal parabolic reflector antenna
- L, S & C Band Reception
- Digital Rotary Scan Head
- Autonomous autotracking
- Multiple mode slave tracking
- Easy maintenance modular design
- DC Brushless overrated motors
- Absolute encoders in all rotating parts with better than 0.05° accuracy
- Optional on bore site video camera
- Bus based internal communication
- Ethernet remote control and monitoring
- No special ACU hardware needed
- Fully integrated auto-calibration system
- Simultaneous receive and optional transmit
- Optional acquisition aid antenna
- Light weight carbon fiber, composite and corrosion resistant construction throughout
- Greatly reduced cabling
- Less weight and better portability
- Windows 7 thru 11 Based ACU Software

For more details contact your local agent or contact JDA Systems directly:

JDA Systems, Gutenbergstrasse 4, 26632 Ihlow Riepe, Germany

Tel: +49-4928-91560 Fax: +49-4928-915620

Web: www.jda-tele.com E-mail: sale@jda-tele.com

Revision 1.1 August 2023



The VuSoft software is used to provide the Antenna Control Unit (ACU) functions. This provides auto calibration, slaved "pointers", Program Tracking, Pre Tracking and Full Autotracking systems together with optional data acquisition and data storage. The VT-012LC is controlled via an Ethernet link that allows the antenna to be placed virtually anywhere that can be reached by a satellite link or WAN making it possible to remote control or slave multiple antennas together even over exceptionally long distances.

Specifications

Operating Frequencies	1435.5-1540.5 & 2185.0-2485.0 & 5090.0-5250.0 MHz
G/T	Approx 6.0 at S-Band
Polarization	Simultaneous dual polarization reception
Main Antenna Gain (Minimum)	22 dBi @ 1435 MHz 26 dBi @ 2350 MHz 32 dBi @ 5150 MHz
Sidelobes	Min -20 dB Under Main Beam @ S-Band
Beam Width	±6.0° @ L-Band ±3.5° @ S-Band ±1.6° @ C-Band
Acquisition Angle	±10° @ L-Band ±7° @ S-Band ±3° @ C-Band
VSWR (Maximum in band)	2:1
Velocity	Up to 60°/sec Azimuth & 60°/sec Elevation
Acceleration	Up to 110°/sec ²
Azimuth Travel	Continuous Unlimited
Elevation Travel	-5 to 187°
Temperature Non-Operating	-40° C to +70° C
Temperature Operating	-30° C (with optional heating) to +65° C Plus Solar
Relative Humidity	Up to 100% Including Condensation
Rain	Up to 5-inches Per Hour
Ice	One-half Inch, Radial
WIND, Operating	110 KPH
WIND, Survival	200 KPH
Weight Approx.	165 kg
Power Requirement	290 W Typical, 460 W Peak
Voltage/Frequency	110/220 VAC, 50/60 Hz, 1 ø
Control Interface	Ethernet
Stabilization	9 axis INU
GPS	Position and Height with Inbuilt Geodetic Model
Transport	Three Provided Ruggedized Transport Cases
Optional Camera	On Axis Fully Integrated Color High Resolution CCD

For more details contact your local agent or contact JDA Systems directly:
JDA Systems, Gutenbergstrasse 4, 26632 Ihlow Riepe, Germany
Tel: +49-4928-91560 Fax: +49-4928-915620
Web: www.jda-tele.com E-mail: sale@jda-tele.com
Revision 1.1 August 2023